

The DBJ-2: A Portable VHF-UHF Roll-Up J-pole Antenna for Public Service

WB6IQN reviews the theory of the dual band 2 meter / 70 cm J-pole antenna and then makes detailed measurements of a practical, easy to replicate, "roll-up" portable antenna.

Edison Fong, WB6IQN

It has now been more than three years since my article on the dual band J-pole (DBJ-1) appeared in the February 2003 issue of *QST*.¹ I have had over 500 inquiries regarding that antenna. Users have reported good results, and a few individuals even built the antenna and confirmed the reported measurements. Several major cities are using this antenna for their schools, churches and emergency operations center. When asked why they choose the DBJ-1, the most common answer was value. When budgets are tight and you want a good performance-to-price ratio, the DBJ-1 (Dual Band J-pole-1) is an excellent choice.

In quantity, the materials cost about \$5 per antenna and what you get is a VHF/UHF base station antenna with $\lambda/2$ vertical performance on both VHF and UHF bands. If a small city builds a dozen of these antennas for schools, public buildings, etc it would cost about \$60. Not for one, but the entire dozen!

Since it is constructed using PVC pipe, it is UV protected and it is waterproof. To date I have personally constructed over 400 of these antennas for various groups and individuals and have had excellent results. One has withstood harsh winter conditions in the mountains of McCall, Idaho for four years.

The most common request from users is for a portable "roll-up" version of this antenna for backpacking or emergency use. To address this request, I will describe how the principles of the DBJ-1 can be extended to a portable roll-up antenna. Since it is the second version of this antenna, I call it the DBJ-2.

Principles of the DBJ-1

The earlier DBJ-1 is based on the J-pole,² shown in Figure 1. Unlike the popular ground plane antenna, it doesn't need ground

¹Notes appear on page 40.

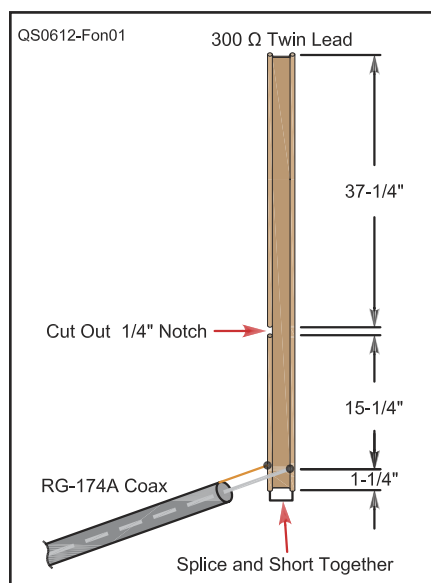

Figure 1 — The original 2 meter ribbon J-pole antenna.

radials. The DBJ-1 is easy to construct using inexpensive materials from your local hardware store. For its simplicity and small size, the DBJ-1 offers excellent performance and consistently outperforms a ground plane antenna.

Its radiation pattern is close to that of an ideal vertical dipole because it is end-fed, with virtually no distortion of the radiation pattern due to the feed line. A vertically polarized, center-fed dipole will always have some distortion of its pattern because the feed line comes out at its center, even when a balun is used. A vertically polarized, center-fed antenna is also physically more difficult to construct because of that feed line coming out horizontally from the center.

The basic J-pole antenna is a half-wave vertical configuration. Unlike a vertical dipole, which because of its center feed is usually mounted alongside a tower or some kind of metal supporting structure, the radia-

tion pattern of an end-fed J-pole mounted at the top of a tower is not distorted.

The J-pole works by matching a low impedance (50Ω) feed line to the high impedance at the end of a $\lambda/2$ vertical dipole. This is accomplished with a $\lambda/4$ matching stub shorted at one end and open at the other. The impedance repeats every $\lambda/2$, or every 360° around the Smith Chart. Between the shorted end and the high impedance end of the $\lambda/4$ shorted stub, there is a point that is close to 50Ω and this is where the 50Ω coax is connected.

By experimenting, this point is found to be about $1\frac{1}{4}$ inches from the shorted end on 2 meters. This makes intuitive sense since 50Ω is closer to a short than to an open circuit. Although the Smith Chart shows that this point is slightly inductive, it is still an excellent match to 50Ω coax. At resonance the SWR is below 1.2:1. Figure 1 shows the dimensions for a 2-meter J-pole. The $15\frac{1}{4}$ inch $\lambda/4$ section serves as the quarter wave matching transformer.

A commonly asked question is, "Why $15\frac{1}{4}$ inches?" Isn't a $\lambda/4$ at 2 meters about $18\frac{1}{2}$ inches? Yes, but twinlead has a reduced velocity factor (about 0.8) compared to air and must thus be shortened by about 20%.

A conventional J-pole configuration works well because there is decoupling of the feed line from the $\lambda/2$ radiator element since the feed line is in line with the radiating $\lambda/2$ element. Thus, pattern distortion is minimized. But this only describes a single band VHF J-pole. How do we make this into a dual band J-pole?

Adding a Second Band to the J-pole

To incorporate UHF coverage into a VHF J-pole requires some explanation. (A more detailed explanation is given in my February 2003 *QST* article.) First, a 2 meter antenna does resonate at UHF. The key word here is

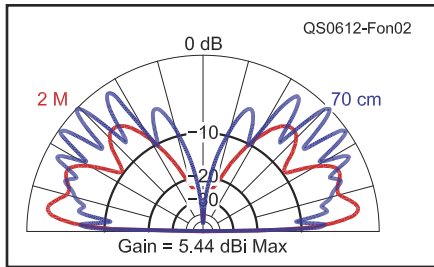

Figure 2 — Elevation plane pattern comparing 2 meter J-pole on fundamental and on third harmonic frequency (70 cm), with the antenna mounted 8 feet above ground. Most of the energy at the third harmonic is launched at 44°.

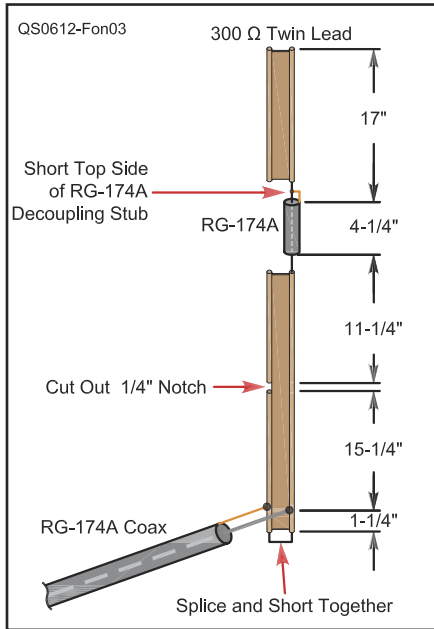

Figure 3 — The original DBJ-1 dual-band J-pole. The dimensions given assume that the antenna is inserted into a 3/4 inch Class 200 PVC pipe.

resonate. For example, any LC circuit can be resonant, but that does not imply that it works well as an antenna. Resonating is one thing; working well as an antenna is another. You should understand that a $\lambda/4$ 146 MHz matching stub works as a $3\lambda/4$ matching stub at 450 MHz, except for the small amount of extra transmission line losses of the extra $\lambda/2$ at UHF. The UHF signal is simply taking one more revolution around the Smith Chart.

The uniqueness of the DBJ-1 concept is that it not only resonates on both bands but also actually performs as a $\lambda/2$ radiator on both bands. An interesting fact to note is that almost all antennas will resonate at their third harmonic (it will resonate on any odd harmonic 3, 5, 7, etc). This is why a 40 meter dipole can be used on 15 meters. The difference is that the performance at the third harmonic is poor when the antenna is

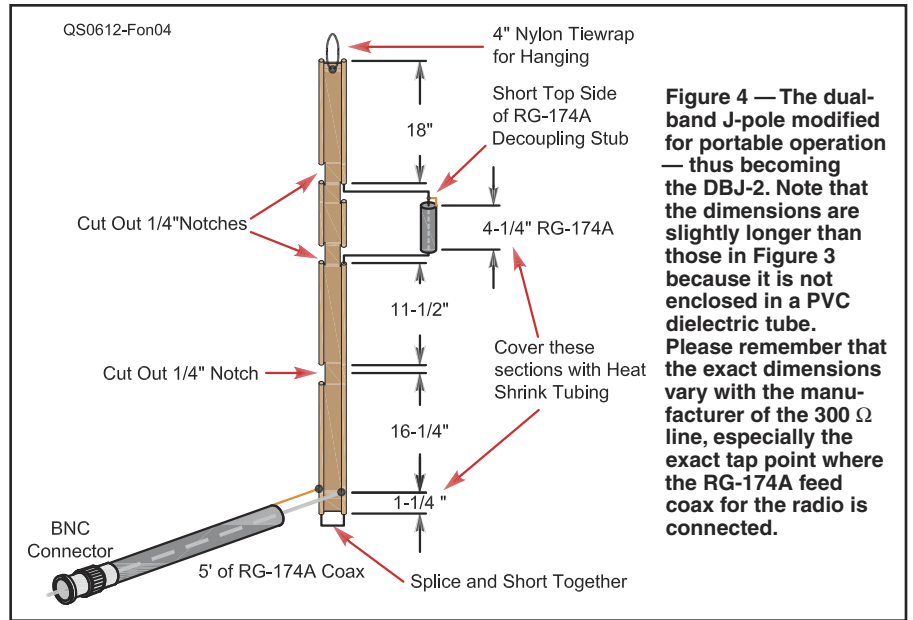

Figure 4 — The dual-band J-pole modified for portable operation — thus becoming the DBJ-2. Note that the dimensions are slightly longer than those in Figure 3 because it is not enclosed in a PVC dielectric tube. Please remember that the exact dimensions vary with the manufacturer of the 300 Ω line, especially the exact tap point where the RG-174A feed coax for the radio is connected.



Figure 5 — The $\lambda/4$ UHF decoupling stub made of RG-174A, covered with heat shrink tubing. This is shown next to the BNC connector that goes to the transceiver.

used in a vertical configuration, as in the J pole shown in Figure 1. This can be best explained by a 19 inch 2 meter vertical over an ideal ground plane. At 2 meters, it is a $\lambda/4$ length vertical (approximately 18 inches). At UHF (450 MHz) it is a $3\lambda/4$ vertical. Unfortunately, the additional $\lambda/2$ at UHF is out of phase with the bottom $\lambda/4$. This means cancellation occurs in the radiation pattern and the majority of the energy is launched at a takeoff angle of 45°. This results in about a 4 to 6 dB loss in the horizontal plane compared to a conventional $\lambda/4$ vertical placed over a ground plane. A horizontal radiation pattern obtained from EZNEC is shown in Figure 2. Notice that the $3\lambda/4$ radiator has most of its energy at 45°.

Thus, although an antenna can be made to work at its third harmonic, its performance is poor. What we need is a simple, reliable method to decouple the remaining $\lambda/2$ at UHF of a 2 meter radiator, but have it remain electrically unaffected at VHF. We want independent $\lambda/2$ radiators at both VHF and UHF frequencies. The original DBJ-1 used a combination of coaxial stubs and 300 Ω twinlead cable, as shown in Figure 3.

Refer to Figure 3, and start from the left hand bottom. Proceed vertically to the RG-174A lead in cable. To connect to the antenna, about 5 feet of RG-174A was used with a BNC connector on the other end. The $\lambda/4$ VHF impedance transformer is made from 300 Ω twin lead. Its approximate length is 15 inches due to the velocity factor of the 300 Ω material. The $\lambda/4$ piece is shorted at the bottom and thus is an open circuit (high impedance) at the end of the $\lambda/4$ section. This matches well to the $\lambda/2$ radiator for VHF. The 50 Ω tap is about 1/4 inches from the short, as mentioned before.

For UHF operation, the $\lambda/4$ matching stub at VHF is now a $3\lambda/4$ matching stub. This is electrically a $\lambda/4$ stub with an additional $\lambda/2$ in series. Since the purpose of the matching stub is for impedance matching and not for radiation, it does not directly affect the radiation efficiency of the antenna. It does, however, suffer some transmission loss from the additional $\lambda/2$, which would not be needed if it were not for the dual band operation. I estimate this loss at about 0.1 dB. Next comes the $\lambda/2$ radiating element for UHF, which is about 12 inches. To

Table 1
Measured Relative Performance of the Dual-band Antenna at 146 MHz

VHF $\lambda/4$ GP 4 radials	VHF Flexible Antenna	Standard VHF J-Pole	Dual-Band J-Pole
0 dB reference	-5.9 dB	+1.2 dB	+1.2 dB

Table 2
Measured Relative Performance of the Dual-band Antenna at 445 MHz

UHF $\lambda/4$ GP 4 radials	UHF Flexible Antenna	Standard VHF J-Pole	Dual-Band J-Pole
0 dB reference	-2.0 dB	-5.5 dB	0.5 dB

make it electrically terminate at 12 inches, a $\lambda/4$ shorted stub at UHF is constructed using RG-174A. The open end is then connected to the end of the 12 inches of 300 Ω twinlead. The open circuit of this $\lambda/4$ coax is only valid at UHF. Also, notice that it is 4½ inches and not 6 inches due to the velocity factor of RG-174A, which is about 0.6.

At the shorted end of the 4½ inch RG-174A is the final 18 inches of 300 Ω twinlead. Thus the 12 inches for the UHF $\lambda/2$, the 4½ inches of RG-174A for the decoupling stub at UHF, and the 18 inches of twinlead provide for the $\lambda/2$ at 2 meters. The total does not add up to a full 36 inches that you might think. This is because the $\lambda/4$ UHF RG-174A shorted stub is inductive at 2 meters, thus slightly shortening the antenna.

Making it Portable

The single most common question that people asked regarding the DBJ-1 is how it could be made portable. The original DBJ-1 had the antenna inserted into Class 200 PVC pipe that was 6 feet long. This was fine for fixed operation but would hardly be suitable for portable use. Basically the new antenna had to have the ability to be rolled up when not in use and had to be durable enough for use in emergency communications.

The challenge was to transfer the concepts developed for the DBJ-1 and apply them to a durable roll-up portable antenna. After much thought and experimenting, I adopted the configuration shown in Figure 4.

The major challenge was keeping the electrical characteristics the same as the original DBJ-1 but physically constructing it from a continuous piece of 300 Ω twinlead. Any full splices on the twinlead would compromise the durability, so to electrically disconnect sections of the twinlead, I cut small ¼ inch notches to achieve the proper resonances. I left the insulating backbone of the 300 Ω twinlead fully intact. I determined the two notches close to the $\lambda/4$ UHF decoupling stub by experiment to give the best SWR and bandwidth.

Because this antenna does not sit inside a dielectric PVC tube, the dimensions are about 5% longer than the original DBJ-1.

I used heat shrink tubing to cover and protect the UHF $\lambda/4$ decoupling stub and the four ¼ inch notches. Similarly, I protected with heat shrink tubing the RG-174A coax interface to the 300 Ω twinlead. I also attached a small Teflon tie strap to the top of the antenna so that it may be conveniently attached to a nonconductive support string.

Figure 5 shows a picture of the $\lambda/4$ UHF matching stub inside the heat shrink tubing. The DBJ-2 can easily fit inside a pouch or a large pocket. It is far less complex than what would be needed for a single band ground plane, yet this antenna will consistently outperform a ground plane using 3 or 4 radials. Setup time is less than a minute.

I've constructed more than a hundred of these antennas. The top of the DBJ-2 is a high impedance point, so objects (even if they are nonmetallic) must be as far away as possible for best performance. The other sensitive points are the open end of the $\lambda/4$ VHF matching section and the open end of the $\lambda/4$ UHF decoupling stub.

As with any antenna, it works best as high as possible and in the clear. To hoist the antenna, use non-conducting string. Fishing line also works well.

Measured Results

I measured the DBJ-2 in an open field using an Advantest R3361 Spectrum Analyzer. The results are shown in Table 1. The antenna gives a 7 dB improvement over a flexible antenna at VHF. In actual practice, since the antenna can be mounted higher than the flexible antenna at the end of your handheld, results of +10 dB are not uncommon. This is the electrical equivalent of giving a 4 W handheld a boost to 40 W.

The DBJ-2 performs as predicted on 2 meters. It basically has the same performance as a single band J-pole, which gives about a 1 dB improvement over a $\lambda/4$ ground plane antenna. There is no measurable degradation in performance by incorporating the UHF capability into a conventional J-pole.

The DBJ-2's improved performance is apparent at UHF, where it outperforms the single band 2 meter J-pole operating at UHF by about 6 dB. See Table 2. This

is *significant*. I have confidence in these measurements since the flexible antenna is about -6 dB from that of the $\lambda/4$ ground plane antenna, which agrees well with the literature.

Also notice that at UHF, the loss for the flex antenna is only 2.0 dB, compared to the ground plane. This is because the flexible antenna at UHF is already 6 inches long, which is a quarter wave. So the major difference for the flexible antenna at UHF is the lack of ground radials.

Summary

I presented how to construct a portable, roll-up dual-band J-pole. I've discussed its basic theory of operation, and have presented experimental results comparing the DBJ-2 to a standard ground plane, a traditional 2 meter J-pole and a flexible antenna. The DBJ-2 antenna is easy to construct, is low cost and is very compact. It should be an asset for ARES applications. It offers significant improvement in both the VHF and UHF bands compared to the stock flexible antenna included with a hand-held transceiver.

If you do not have the equipment to construct or tune this antenna at both VHF and UHF, the antenna is available from the author tuned to your desired frequency. Cost is \$20. E-mail him for details.

Notes

¹E. Fong, "The DBJ-1: A VHF-UHF Dual-Band J-Pole," *QST*, Feb 2003, pp 38-40.

²J. Reynante, "An Easy Dual-Band VHF/UHF Antenna," *QST*, Sep 1994, pp 61-62.

Ed Fong was first licensed in 1968 as WN6IQN. He later upgraded to Amateur Extra class with his present call of WB6IQN. He obtained BSEE and MSEE degrees from the University of California at Berkeley and his PhD from the University of San Francisco. A Senior Member of the IEEE, he has 8 patents, 24 published papers and a book in the area of communications and integrated circuit design. Presently, he is employed by the University of California at Berkeley teaching graduate classes in RF design and is a Principal Engineer at National Semiconductor, Santa Clara, California working with CMOS analog circuits. You can reach the author at edison_fong@hotmail.com. 

Building an Emergency J-Pole

By Phil Karras, KE3FL

June 15, 1999

This type of J-Pole has been written about in QST, and the description has appeared elsewhere (see "Bibliography," below). The J-Pole is not difficult to make, even for a beginner. This antenna works well on 2-meters; it also works on 440 MHz.

If you look at the antenna, it is a $3/4$ -wavelength radiating section attached to the matching stub by the shorting bar; all together it looks like the letter J, hence the name J-pole.

Read all of these instructions before beginning your construction project. Nothing is more frustrating than doing something, only to find a hint afterwards that would have made the project go smoother.

See below for a listing of parts and tools you'll need to make up this simple antenna.

Some Past J-Pole Articles in QST:

- *QST* Jul 1995, p 62, "Build a Weatherproof PVC J-Pole Antenna,"
- *QST* Jun 1995, p 71, "Try A 2-Meter Flexi-J Antenna"
- *QST* Sep 1994, p 61, "An Easy Dual-Band VHF/UHF Antenna"
- *QST* Apr 1982, p 43, (This was the article for a wire J-pole antenna I was able to find in *QST*).

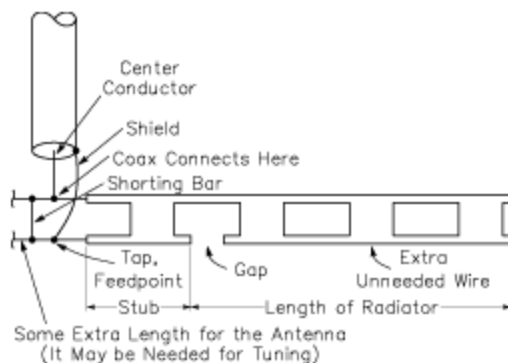

Larger picture available [here](#).

Using "ladder line" is a bit different than using solid-dielectric TV twinlead. Before cutting, stretch out the wire so that you can position the proposed cuts at a position that has a center plastic support, and not at a position that has no center plastic. This may not be possible for both the $1/4$ -wavelength section and the total length position. If it comes down to a choice, I recommend selecting the support at the top.

This plastic melts well and can be melted back together. I have had to melt sections back together in both locations, and the antennas work just fine and hold up to field rigors.

Select the bottom of the antenna and strip off about 3 to 3-1/2 inches of insulation from both wires. Tack solder (temporary solder joint) a piece of wire as a shorting bar about 1 inch from the bottom of the antenna (this bar may need to be moved).

To start with, the coax will be connected about 1-1/4 inch from the shorting bar. This connection and the shorting bar connection may need to be moved in order to achieve the best SWR and frequency match.

Measure 17 inches up from the shorting bar on *one end only* and cut a 1/4-inch gap in the wire at this position. (You can melt the plastic back together at this location if needed.)

Now measure 52-1/4 inches up from the shorting bar. If this location has no center plastic support, try to remove as little insulation as needed in order to get at the wire and snip it. Cut out at least one inch of wire, then melt the plastic back onto the locations where you removed it.

I use a sharp knife to cut into the insulation and not into the wire. Then I pry the wire out with a pin and snip it or solder it at the correct location.

Preparing the Coax

Bend the coax about an inch from the end, and score the insulation with a sharp knife. This cuts into the insulation without damaging the shield if done gently. Then rotate the coax so you can continue scoring the coax until it is cut all the way around. Cut the insulation from the new cut, up to the end of the coax. You should now be able to pull off the insulation with pliers.

Remember to always cut *away* from yourself!

Never use wire strippers on the large portion of the coax; it only damages the shield. If you have a tool designed for coax, use it.

Prepare the antenna end of the coax: Separate the coax shield and twist it together. Strip off about 3/4-inch of insulation from the center conductor of the coax. (Do *not* solder at this time.)

You'll install the appropriate connector (BNC, PL-259) at the other end of the coax. Follow the installation directions that come with the connector, or consult *The ARRL Handbook* for more information.

Connecting Coax to Antenna

Wrap the shield 1-1/4 inch up from the shorting bar around the 17-inch side of the twin lead. Wrap it in such a way that the distance from the coax to the shorting bar is the same for both the shield and the center conductor. Solder the shield to the twin lead.

Wrap the center coax conductor around the longer twin lead wire up from the shorting bar (the same distance that the shield is wrapped to the other wire) and solder it.

Cut off the excess coax wire. Also, cut off all the excess twin lead at the top except for a loop or two. These ladder steps are great for hanging the antenna over a nail or hook, so leave at least one of them.

Your antenna is now ready to test.

Testing Your J-Pole

Get your VHF SWR analyzer or meter. Hang the antenna away from all objects (I hang mine from the top of a window and this seems to work almost as well as from a tree).

For best SWR measurements, the antenna should be at least 2 wavelengths away from any object. (For 2-meters this is approximately 13 feet.)

Set your radio for lowest power and 146.000 MHz simplex. Test out the antenna for 144.000 and 148.000 as well. If all three are below 1.7 SWR and the SWR for 146 is about 1.3 or lower, you are done. If not, see for the sidebar "Help for Lowering the SWR, Changing the Frequency, and Increasing the Bandwidth" below.

Once you are done, slip the shrink tubing onto the antenna over the coax connections, squirt some electrical-connection safe RTV into the bottom of the shrink tubing, and then heat up the tubing from the bottom up. This should push (squeeze) some RTV all the way to the top of the shrink tubing. Wipe off the excess and hang the antenna for 12 to 24 hours to let the RTV dry.

The SWR at 146.0 should be close to and below 1.3 to 1; for 144.0 and 148.0, it should be 1.7 to 1 or lower. If you have difficulty obtaining these results, see "Help for Lowering the SWR, Changing the Frequency, and Increasing the Bandwidth", below.

At 445.0 MHz, the antenna should read below 1.5 to 1. I have not checked it out as thoroughly as I have 2 meters, but I do know that it is not a nice one-dip curve; rather, it is a multiple dip/peak curve.

***Editor's note:** Philip Karras, KE3FL, lives in Mt Airy, Maryland. An ARRL Life Member, he holds a field appointment as Assistant Emergency Coordinator in Carroll County, Maryland. He's also an OES, ORS, and a volunteer examiner. He may be contacted via e-mail to ke3fl@arrl.net. Visit his Web site at <http://www.qsl.net/ke3fl>.*

PARTS LIST:

5 feet of 450-ohm ladder line
20 feet of RG-58 or similar coax
2 inches of heat-shrinkable tubing

NECESSARY TOOLS:

Soldering iron (20-30 W)
Solder
Wire cutters
Wire strippers
VHF SWR meter or antenna analyzer
Sharp knife
Pliers
RTV silicone sealant
Heat gun or hair dryer (for heat-shrinkable tubing)

Help for Lowering the SWR, Changing the Frequency, and Increasing the Bandwidth

If your antenna did not have a nice low SWR at the desired center frequency, try moving the shorting bar down about 0.1 inch at a time until you get the lowest SWR you can--even if this is nowhere close to 1:1. You may have to move it back up if you go too far. Normally I find that I have to move the shorting bar down, ie, *away from the feed-point*, but it's always possible that it will need to go the other way too.

If you have already cut the extra wire off the bottom of the antenna, you will need to add some back if moving the shorting bar closer to the feed-point only makes the SWR worse. Add about two inches to both the matching stub and radiator at the bottom of the antenna.

Once the position of the shorting bar to the feed point that produces the lowest SWR has been found, move the coax contact points and the shorting bar together until you can get this lowest SWR match at the desired frequency. The *important* point to remember here is that the distance between the feed-point and the shorting bar determines the lowest SWR. This distance must *not* change while trying to get the lowest SWR at the desired center frequency.

If the lowest SWR you can get by moving the shorting is not 1:1, it will turn out to be closer to 1:1 once you move both the shorting bar and the coax feed point so that the lowest SWR is at the desired center frequency.

Help on Shifting the Frequency

If you need to shift the frequency and moving the tap point doesn't change it enough, you can cut the J-Pole. You should *not* have to do this for this antenna since the dimensions for this antenna have been worked out over years of experience by many different people.

Here are the two rules of thumb for changing the center frequency of any antenna:

LLL: Longer antenna = Longer wavelength = Lower frequency

SSH: Shorter antenna = Shorter wavelength = Higher frequency

When cutting the antenna shorter, I recommend making only *one-half* the change you calculate. In this way you may be able to prevent making too large a cut and having to undo it.

All changes are interactive, some more so than others, but expect to see SWR changes for length changes, and frequency shifts when moving the shorting bar/feed-point up and down. (Remember to move both the feed-point and the shorting bar in tandem, keeping the distance between them constant when trying to re-center the lowest SWR at the frequency you want.)

Help on Increasing the Bandwidth (BW)

Once again you should not ever have this problem with the 2-meter J-pole since the dimensions have been worked out by calculation and by trial and error by many people. However, if you are trying to design for a new frequency, you might need to be able to change the BW.

A very narrow BW may be an indication that the radiator is too long, or it is too long in relation to the matching stub. I have only performed one experiment so far. In this experiment I added

one inch of wire to the top of a good working J-pole antenna for 2-meters. The bandwidth dropped to about 0.6 MHz. When I removed the extra wire, the BW returned to about 3.8 MHz between 1.7:1 SWR points.

Other things I've tried made such small changes in the bandwidth that I was never sure the data was significant. Was the change due to the method tried or did I do something else a bit differently that caused the change?

An Easy Dual-Band VHF/UHF Antenna

You've just opened the box that contains your new H-T and you're eager to get on the air. But the *rubber duck* antenna that came with your radio is not working well. Sometimes you can't reach the local repeater. And even when you can, your buddies tell you that your signal is noisy.

If you have 20 minutes to spare, why not build a low-cost *J-pole* antenna that's guaranteed to outperform your rubber duck? My design is a dual-band J-pole. If you own a 2-meter/70-cm H-T, this antenna will improve your signal on *both* bands.

Hams throughout the world have built and used J-pole antennas for years. My design is simple, lends itself to experimentation and alternative construction techniques, and has the following features:

□ A 1.7:1 SWR or better throughout most of the 2-meter band and less than 2:1 across the 70-cm band.

□ Easy set up. You can put it on the air in a matter of seconds, or store it in a space no larger than a small paperback book.

□ Simple construction. The entire antenna system can be built in less than 30 minutes using TV twin lead and coaxial cable.

Why settle for the performance your rubber duck antenna offers?

Build this portable J-pole and boost your signal for next to nothing!

By Jim Reynante, KD6GLF
PO Box 27856
San Diego, CA 92198

All of the SWR data in this article was measured at the transmitter end of the feed line. The reference impedance is 50 Ω, since most equipment is designed for this impedance.

J-Pole Antenna Theory

The J-pole is a vertically polarized antenna with two elements: the radiator and the matching stub. Although the antenna's radiator and stub are $\frac{3}{4}$ wavelength and $\frac{1}{4}$ wavelength, respectively, it operates as an end-fed half-wave antenna. Here's how you determine the lengths of the J-pole's two elements:

$$L_{3/4} = \frac{8856 \times V}{f}$$

$$L_{1/4} = \frac{2952 \times V}{f}$$

where:

$L_{3/4}$ = the length of the $\frac{3}{4}$ -wavelength radiator in inches

$L_{1/4}$ = the length of the $\frac{1}{4}$ -wavelength stub in inches

V = the velocity factor of the TV twin lead
 f = the design frequency in MHz

These equations are more straightforward than they look. Just plug in the numbers and go. My design assumes that 146 MHz is the center frequency on the 2-meter band. You may, of course, substitute a center frequency of your choice. Even though the antenna is designed using a 2-meter center frequency, it also works well on 70 cm—as you'll see later.

Don't let the *velocity factor* throw you. The concept is easy to understand. Put simply, the time required for a signal to travel down a length of wire is *longer* than the time required for the same signal to travel the same distance in free space. This delay—the velocity factor—is expressed in

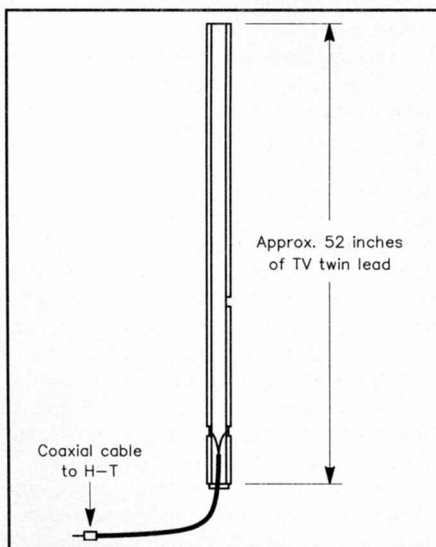

Figure 1—The J-pole antenna is approximately 52 inches long and may be hung from just about anywhere.

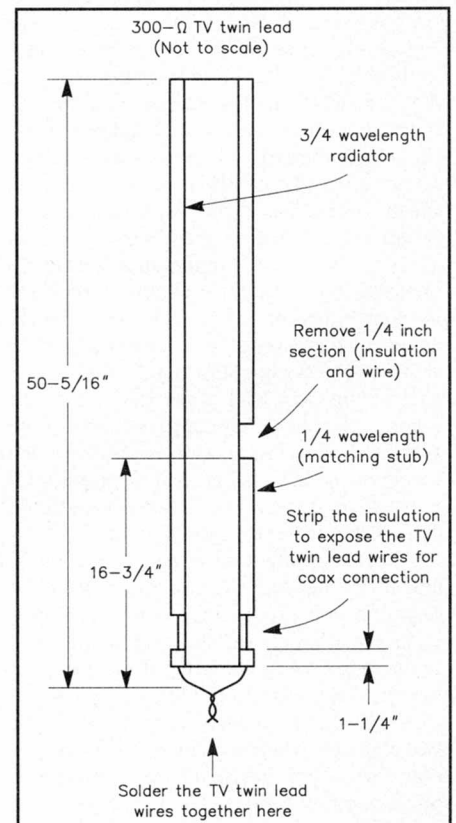

Figure 2—The basic J-pole layout. Note the areas where insulation and/or wire must be trimmed.

terms of the speed of light, either as a percentage or a decimal fraction. Knowing the velocity factor is important when you're building antennas and working with transmission lines. Because of the delay, 360° of a given signal wave exists in a physically shorter distance on a wire than in free space. This shorter distance is the *electrical* length, and that's the length we need to be concerned about.

Copper wire has a velocity factor of about 0.93, whereas TV twin lead has a velocity factor of 0.81 to 0.85 depending on who made it. If you're unsure about the twin lead you're using, just use 0.85 as its velocity factor. It's okay if it turns out to be too high. You'll be able to compensate by trimming the antenna. (It's better for the antenna to be too long than too short!) The TV twin lead I used had a velocity factor of 0.83. So, using the formulas, at 146 MHz the lengths would be approximately 50⁵/₁₆ inches for the 3/4-wavelength radiator and 16³/₄ inches for the 1/4-wavelength stub.

Construction

Because of the few materials needed to construct this antenna, you'll find it surprisingly easy to build. Start with approximately five feet of 300-Ω TV twin lead and about six feet of 50-Ω coaxial cable (see Figure 1) with a suitable connector (most H-Ts use a BNC connector). Use only flat 300-Ω TV twin lead, not foam core. RF can potentially short through the foam core.

Start by stripping off 1/2 inch of insulation at one end of the TV twin lead (see Figure 2). Solder the two exposed wires together. This is the bottom of the antenna. Next, measure up 1 1/4 inches from the soldered wires and remove the insulation from the twin lead to expose 1/8 to 1/4 inch of wire on both sides. Be careful not to nick or break these wires. They are your connection points for the coaxial feed line.

Now you're ready to measure and cut the elements of the antenna. On one side of the twin lead, measure up 50⁵/₁₆ inches from the center of the exposed wire and trim off the twin lead entirely (both conductors). This side of the twin lead is the radiator of the J-pole antenna. On the opposite side of the twin lead, measure up 16³/₄ inches from the center of the exposed wire and carefully remove a 1/4-inch section of insulation and wire. This is the 1/4-wavelength matching stub.

Turn your attention to the coaxial cable and strip the end without the connector. Separate and expose the center conductor from the braided shield. Attach the coax to the twin lead by soldering the center conductor of the coax to the longer element of the J-pole and the shield to the shorter of the two elements. Do this at the point where you removed the twin lead insulation and exposed the wire on both sides (see Figure 3).

Apply a generous amount of weather-proof silicon sealant to the exposed coax to prevent moisture from seeping into the line. Now tape the coax to the twin lead to relieve

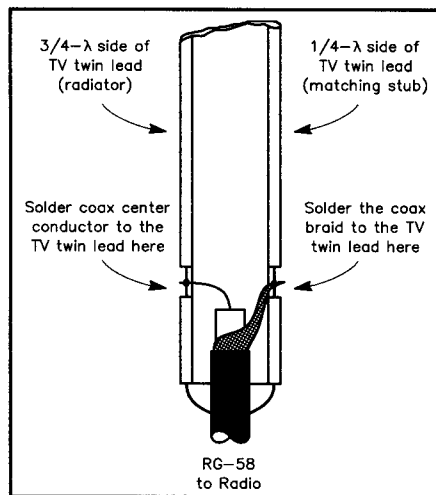

Figure 3—The coaxial feed line is connected directly to the antenna. Be careful to observe that the center conductor is soldered to the side of the TV twin lead with the longer conductor. The braid is connected to the side with the shorter conductor.

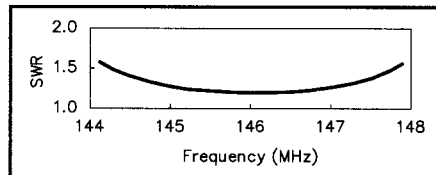

Figure 4—The SWR of the J-pole over the 2-meter band.

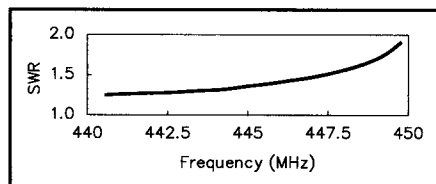

Figure 5—On the 70-cm band, the J-pole still presents a useable SWR.

strain on the soldered connection points. Heat shrink tubing also works well for this application.

Tuning

Hang your J-pole vertically by making a small hole at the top of the antenna and tying a length of twine or fishing line. Take care to keep the antenna away from metal objects that could detune it.

Tuning the J-pole is easy. Using a high-accuracy VHF/UHF SWR meter (borrow one if necessary), simply trim the length of the elements until you read a 1:1 SWR—or as close as you can get. Trim in *very* small increments; don't chop off an inch at a time! Remember to trim in a 3:1 ratio to maintain the 3/4- to 1/4-wavelength proportions. For example, if you cut 1/8 inch from the 1/4-wavelength stub, you must cut 3/8 inches from the 3/4-wavelength radiator (1/8 × 3 = 3/8).



I should mention that this design can cause RF coupling to the feed line. To avoid this, you can place ferrite beads on the coax at the feedpoint. An alternative is to use 3 to 5 turns of coax (1 to 2 inches in diameter) to create an RF choke at the feedpoint.

Results

Figure 4 shows my SWR measurements on 2 meters. As you can see, the antenna displayed a fairly flat SWR over most of the 2-meter band. At no point did it exceed 1.7:1. I achieved slightly higher, but useable, results on 70 cm (see Figure 5).

After hanging my J-pole from a tree limb and connecting my H-T, I switched to the frequency of a nearby repeater and gave it a try. I was able to talk with several local hams and they all said my signal sounded strong and clear. So far so good, but now came the true test. I switched to a repeater located about 17 miles north of my home, one that I couldn't use with my rubber duck antenna. I keyed the transceiver, announced my call sign, and was almost immediately greeted by a friendly voice. It worked! And not only that, it worked pretty well. The other ham said I was full-quieting into the repeater. Not bad for less than 30 minutes of work. Reception performance was also improved.

Summary

A J-pole antenna will never replace a beam or a full-size vertical mounted at 30 feet, but it offers relatively good performance for a minimum of materials, time and effort.

The applications of this antenna go beyond emergency or portable use. A permanent weatherproof enclosure can be built by mounting the J-pole inside a length of PVC tubing capped at the top. The PVC tube may then be placed at the top of a mast or similar structure. You can drill a small hole in the side of the PVC tube for the coax. Just make sure to seal it against the weather. The PVC will protect the antenna and can be painted to match the color of your house or apartment. If you live in an area where you can't put up outside antennas, hang the J-pole in your attic! If the antenna is located more than 10 feet from your radio, use a low-loss coaxial feed line such as RG-213 or equivalent.

Because of the low cost, simple construction, compact size and improved performance, there's no reason not to build several of these antennas. Keep one rolled up in your backpack when hiking, or in the glove compartment of your car! **QST**

Q: I built the dual-band J-pole antenna from the article in the September 1994 *New Ham Companion* (“An Easy Dual-Band VHF/UHF Antenna,” page 61), but I just can’t get it to work. What can I do?

A: Try adding a balun to the coax. A balun is necessary because a J-pole antenna uses a balanced feed (the 1/4-wavelength matching section) connected to an unbalanced feed line (the coax). The simplest way to make a balun is to get a split-core cylindrical ferrite (such as an Amidon 2X-43-251) and attach it to the outside of the coax 1/4 wavelength from the feedpoint. On VHF frequencies some ferrite materials are not effective, so be sure to get type 43 material for best results.

Another thing you may want to do is lengthen the antenna a bit. The formula for the antenna length in the article is unintentionally misleading. Because the 1/2-wavelength radiator is not a feed line, it has a much higher velocity factor than that of twin lead. The velocity factor of copper wire is about 0.95, so the 1/2-wave radiator section should be 38-3/8 inches long.

